

PACKAGED ELECTRIC WATER HEATER

**15 - 1600 KW - ALL VOLTAGES & PHASES,
80 - 5000 GALLON CAPACITY**

Model SH & H

FEATURES

- **Reliable**
 - Only high grade materials used in construction to ensure long operating life
 - Hydrastone cement lining provides superior protection and tank longevity
 - Heavy duty construction withstands demanding commercial/industrial use
- **Packaged System**
 - Fully packaged water heater saves time and money during installation
 - All electrical operating controls are factory selected and wired to ensure reliable operation
- **Versatile**
 - Full range of styles, sizes, and optional features to meet your exact water heating needs
 - Highly efficient design lowers peak power demand and reduces operating costs

APPLICATIONS

- Schools
- Office Buildings
- Prisons
- Stadiums
- Hotels
- Industrial Facilities
- Nursing Homes
- Hospitals



Model SH and H



*Model SH,
Vertical Configuration*



A HEAVY DUTY STORAGE ELECTRIC WATER HEATER

The Model SH and H is a fully packaged water heater designed to be a reliable and long lasting source for hot water. Each component is carefully selected to ensure performance in even the most demanding application. Whether you are heating potable water in a commercial building or heating process water in an industrial application you can

select a Hubbell Model SH or H to do the job. When you specify and install a Hubbell SH or H model water heater you will have confidence in knowing that the owner will be provided with a quality product that is a long lasting and trouble free source for hot water.

A PACKAGED ELECTRIC WATER HEATER READY FOR INSTALLATION

HubbellTM

CEMENT LINED TANKS PROVIDE LONGER SERVICE LIFE



What is the most common reason why a water heater fails?



Failure of a tank's *protective lining* allows water to come into direct contact with the steel tank causing it to *corrode* and *leak*.

Therefore, the type of protective lining is the single most important feature when determining the quality of any water heater. The ability of a lining to protect the steel tank is primarily based upon its thickness and complete coverage of all steel surfaces.

LININGS AVAILABLE FOR A STEEL TANK

1. Cement Lining

A specially formulated Hydrastone cement applied to a minimum of $\frac{5}{8}$ " thickness on all surfaces. The cement lining covers 100% of all interior surfaces and is 125 times thicker than glass lining. Due to the thickness and guaranteed coverage of cement lining there is no need for a sacrificial anode. An extremely durable and long lasting lining suitable for hot and cold potable water storage in a variety of commercial and industrial applications.

2. Phenolic Lining

An epoxy coating applied in 2 coats to a total of 10-12 mils DFT. Typically used in process applications using low conductivity DI, distilled, or food grade water.

3. Copper Lining

A 3 lb./sq.ft. copper sheet approximately .0646" thick covers all interior surfaces. All copper sheet seams are factory tested to ensure long lasting protection of the steel vessel.

4. Flame-Spray Copper

Molten copper is sprayed on interior surfaces to a thickness of 5-6 mils. The copper bonds to the steel, and an additional overcoat of Phenolic lining is applied on the copper to seal all pores.

5. Galvanizing

The steel pressure vessel is pickled and hot dipped in molten zinc to create a barrier which internally and externally protects a steel vessel for cold and hot water storage.

NON-FERROUS TANKS

A solid Non-Ferrous tank does not require a lining because the pressure vessel itself is constructed from material which is impervious to the corrosive effects of hot water. This type of tank will provide a significantly longer service life than all lined steel tanks, but is initially more costly.

1. Copper-Silicon

A pressure vessel constructed from solid copper-silicon alloy offers tremendous tank longevity due to its ability to withstand the cycling effects induced from changes in water temperature and pressure. An extremely long lasting vessel suitable for storage of hot potable water in a variety of commercial and industrial applications.

2. 90/10 Copper-Nickel

A 90% Copper 10% Nickel alloy similar to copper-silicon, but with added strength and corrosion resistance. Typically used in applications with corrosive environments (salt water) or in critical commercial and industrial applications requiring long tank life.

3. Stainless Steel

Stainless steel (Specify: Type 304, 316, or 316L) is well suited for industrial and high purity applications requiring a corrosion resistant tank with minimal leaching of impurities into the water. Well suited for process, RO, and DI water systems in the pharmaceutical, food, and electronic industries.

SH / H MODEL STANDARD EQUIPMENT

Vessel Construction

1. All welded carbon steel vessel designed and built in strict accordance with the ASME Code Section IV and stamped, certified, and registered with the National Board of Boiler and Pressure Vessel Inspectors.
2. All internal tank surfaces are lined with a minimum of $\frac{5}{8}$ " thick Hydrastone cement for superior protection and tank longevity.
3. Designed for 125psi working pressure and hydrostatically tested at 188psi ($1\frac{1}{2}$ times the WP).

General

1. Heavy duty 2" thick fiberglass blanket insulation covers 100% of the pressure vessel for maximum operating efficiency and minimal standby heat loss.
2. Heavy gauge galvanized steel protective jacket with both top and bottom heads keeps insulation in place and protected to ensure high efficiency during operation.
3. Entire vessel is supported on heavy duty integrally welded steel supports for sturdy floor mounting.
4. Full five (5) year Non Pro-Rated tank warranty and one (1) year electrical component warranty.
5. Bronze ASME rated combination temperature and pressure safety relief valve set at the vessel working pressure and 210°F.

Electrical Operating Controls

1. All electrical operating controls are factory sized, selected, wired, tested, and mounted in a NEMA I enclosure to ensure safe and reliable operation.
2. A power distribution block is supplied for single point electrical installation.
3. Fast acting power fuses rated at a maximum of 60 Amps protect each heating element branch circuit per NEC and UL requirements. Each branch circuit has a maximum rating of 48 Amps.
4. Heavy duty definite purpose magnetic contactor with integrally mounted power fuse block assembly switches power on/off to each branch circuit.
5. Heavy duty removable flange type copper sheathed immersion heating element provides long service life.
6. Fully adjustable thermostat maintains accurate water temperature and is sized by the factory to control the appropriate number of heating element circuits.
7. A generously sized transformer provides fused 120V to the control circuit
8. A fully adjustable (100-240°F) safety hi-limit device with manual reset interrupts power to the control circuit in the event of over-temperature water in the storage tank.
9. Safety door interlock mechanism interrupts power to the control circuit upon opening the electrical control panel.
10. Louvers in the control panel allow for cooling of the electrical components to ensure maximum electrical component longevity.

SH / H MODEL OPTIONAL EQUIPMENT

NOTE: Other optional features are available, please consult factory if required.

Vessel

- 1A. Alternate protective lining:**
Phenolic epoxy resin, Flame spray copper, 3lbs./Sq.Ft. Copper lining, Hot dip galvanizing, other.
- 1B. Alternate vessel construction:**
Stainless Steel Type 304 or 316L, 90/10 Copper-Nickel, Copper-Silicon, other.
- 1C. Alternate working pressure:**
Please specify

Electrical

- 1.** NEMA 4 watertight enclosure for outdoor/wet locations.
- 2.** Explosion resistant enclosure for hazardous locations.
- 3.** Built-in circuit breaker (with or without shunt trip) or a built-in non-fused On/Off disconnect switch.
- 4.** Alternate element sheath material (Please Specify: Incoloy, Stainless Steel, other).
- 5.** Specialized heating element construction including: Special watt density rating, passivation, electropolishing, or any other feature required to meet the needs of your application.

General

- 1.** Skid mounting on heavy duty all welded I Beam
- 2.** Type 304 stainless steel protective jacket, please specify if painted.
- 3.** Dual energy package provides operational flexibility for electric and (steam or boiler water) power.
- 6.** Factory installed low water cut out device to disengage electrically the heating element(s) in the event of insufficient water in the tank.
- 7.** Dial thermometer and pressure gauge factory installed in the tank.
- 8.** Intra-tank circulation pump package with On/Off switch to continuously circulate water within the tank and thereby reduce stratification. All bronze circulator pump is rated 1/12 HP, 120V, 1 Ph.
- 9.** Status indicating lamp(s).
- 10.** Audible alarm system.
- 11.** Digital display electronic temperature controller. Please specify with or without RS485 communication port for remote operation of the temperature controller.
- 12.** Building Automation System (BAS) package provides remote operating/alarm capability.

OUTLINE DIMENSIONS

MODEL SH (VERTICAL)

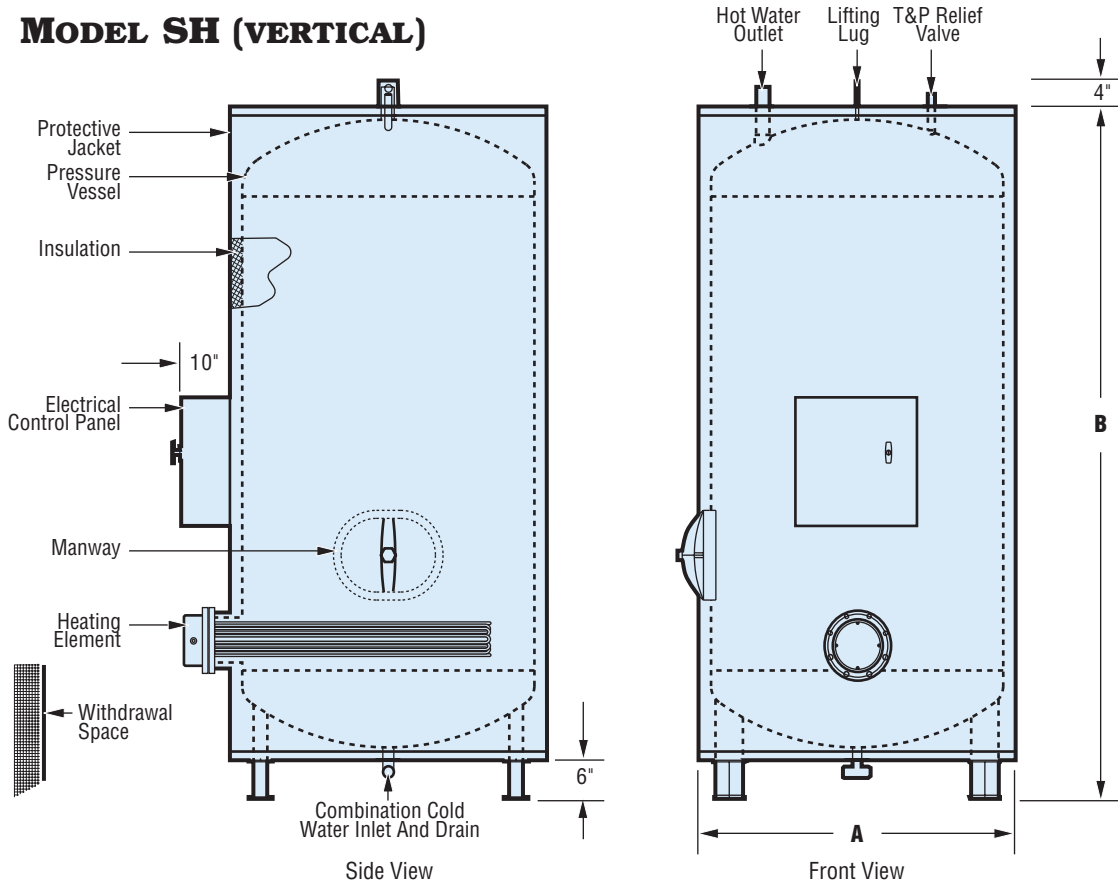

MODEL H (HORIZONTAL)

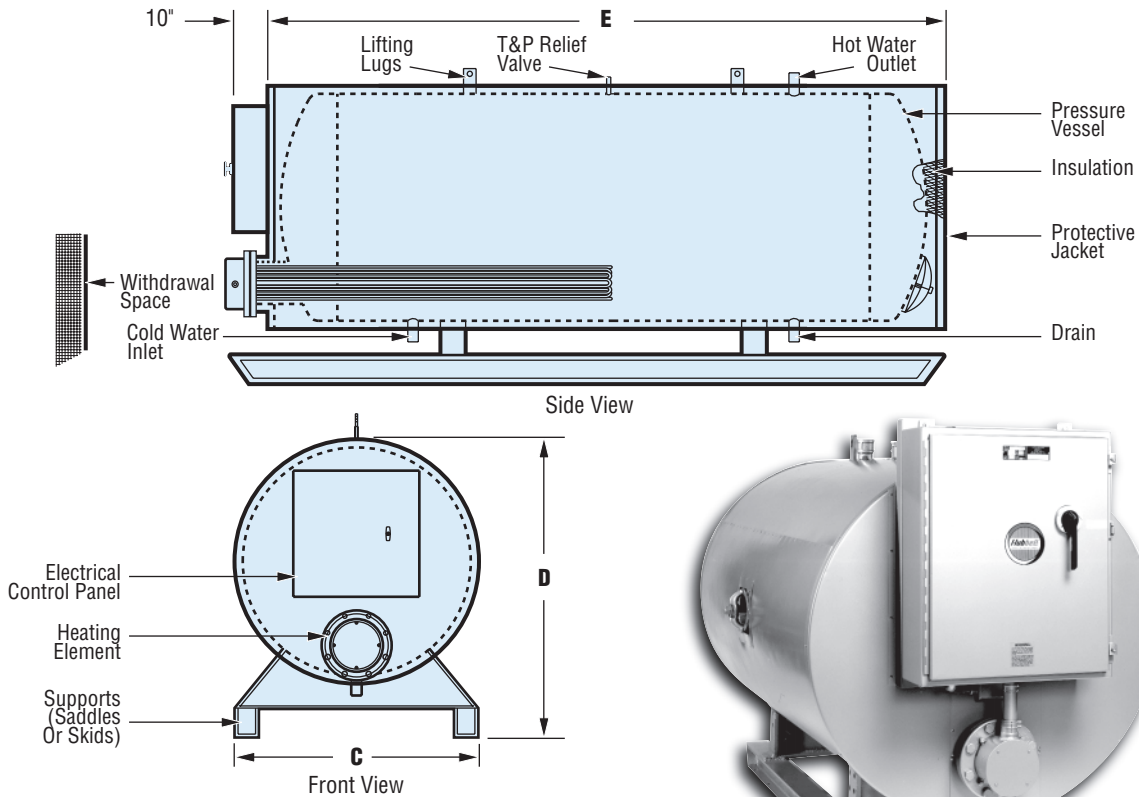

OVERALL DIMENSIONS, MODELS SH AND H

| Storage Capacity (Gallons) | Overall Dimensions (Inches) | | | | | Storage Tank Diameter x Length | Inlet Outlet Sizing (NPT) | Approx. Shipping Weight (Lbs.) |
|----------------------------|-----------------------------|------------|------------|------------|------------|--------------------------------|---------------------------|--------------------------------|
| | Vertical | | Horizontal | | | | | |
| | Diameter "A" | Height "B" | Width "C" | Height "D" | Length "E" | | | |
| 80 | 28 | 56 | 28 | 34 | 50 | 24 x 46 | 1.5 | 1000 |
| 120 | 28 | 75 | 28 | 34 | 69 | 24 x 65 | 1.5 | 1150 |
| 150 | 34 | 65 | 34 | 40 | 59 | 30 x 55 | 1.5 | 1300 |
| 175 | 34 | 73 | 34 | 40 | 67 | 30 x 63 | 1.5 | 1500 |
| 200 | 34 | 82 | 34 | 40 | 76 | 30 x 72 | 1.5 | 1700 |
| 225 | 34 | 89 | 34 | 40 | 83 | 30 x 79 | 1.5 | 1750 |
| 250 | 40 | 74 | 40 | 46 | 68 | 36 x 64 | 1.5 | 1850 |
| 275 | 40 | 80 | 40 | 46 | 74 | 36 x 70 | 1.5 | 2000 |
| 300 | 40 | 88 | 40 | 46 | 82 | 36 x 78 | 1.5 | 2180 |
| 325 | 40 | 92 | 40 | 46 | 86 | 36 x 82 | 1.5 | 2300 |
| 350 | 40 | 94 | 40 | 46 | 88 | 36 x 84 | 1.5 | 2500 |
| 375 | 46 | 81 | 46 | 52 | 75 | 42 x 71 | 1.5 | 2600 |
| 400 | 46 | 85 | 46 | 52 | 79 | 42 x 75 | 1.5 | 2700 |
| 425 | 46 | 88 | 46 | 52 | 82 | 42 x 78 | 1.5 | 2900 |
| 450 | 46 | 93 | 46 | 52 | 87 | 42 x 83 | 1.5 | 3000 |
| 475 | 52 | 79 | 52 | 58 | 73 | 48 x 69 | 2 | 3100 |
| 500 | 52 | 82 | 52 | 58 | 76 | 48 x 72 | 2 | 3225 |
| 525 | 52 | 85 | 52 | 58 | 79 | 48 x 75 | 2 | 3350 |
| 550 | 52 | 89 | 52 | 58 | 83 | 48 x 79 | 2 | 3400 |
| 575 | 52 | 93 | 52 | 58 | 87 | 48 x 83 | 2 | 3500 |
| 600 | 52 | 95 | 52 | 58 | 89 | 48 x 85 | 2 | 3650 |
| 700 | 52 | 107 | 52 | 58 | 101 | 48 x 97 | 2 | 4000 |
| 800 | 52 | 119 | 52 | 58 | 113 | 48 x 109 | 2 | 4300 |
| 900 | 52 | 132 | 52 | 58 | 126 | 48 x 122 | 2 | 4800 |
| 1000 | 52 | 145 | 52 | 58 | 139 | 48 x 135 | 2 | 5200 |
| 1250 | 58 | 149 | 58 | 64 | 143 | 54 x 139 | 2 | 5600 |
| 1500 | 58 | 174 | 58 | 64 | 168 | 54 x 164 | 2 | 6000 |
| 1750 | 64 | 168 | 64 | 70 | 162 | 60 x 158 | 3 | 7400 |
| 2000 | 64 | 185 | 64 | 70 | 179 | 60 x 175 | 3 | 8100 |
| 2500 | 76 | 169 | 76 | 82 | 163 | 72 x 159 | 3 | 8200 |
| 3000 | 76 | 197 | 76 | 82 | 191 | 72 x 187 | 3 | 8300 |
| 3500 | 88 | 174 | 88 | 94 | 168 | 84 x 164 | 6 FLG. | 8900 |
| 4000 | 88 | 195 | 88 | 94 | 189 | 84 x 185 | 6 FLG. | 9800 |
| 4500 | N/A | N/A | 94 | 100 | 178 | 90 x 174 | 6 FLG. | 10700 |
| 5000 | N/A | N/A | 94 | 100 | 100 | 90 x 196 | 6 FLG. | 11600 |
| | | | | | | | | |
| | | | | | | | | |

RECOVERY RATINGS AND AMPERAGE AT SELECTED KW

| KW INPUT | BTU/HR RATING | Gallons Per Hour (GPH) Heated At Various Temperature Rises | | | | | Amperage Rating At Various Voltages | | | | |
|----------|---------------|--|--------|---------|---------|---------|-------------------------------------|---------|---------|---------|---------|
| | | 60°F Δ | 80°F Δ | 100°F Δ | 120°F Δ | 140°F Δ | 208V 3Φ | 240V 3Φ | 380V 3Φ | 415V 3Φ | 480V 3Φ |
| 15 | 51,195 | 103 | 77 | 62 | 51 | 44 | 42 | 36 | 23 | 21 | 18 |
| 20 | 68,260 | 137 | 103 | 82 | 68 | 59 | 56 | 48 | 30 | 28 | 24 |
| 25 | 85,325 | 171 | 128 | 103 | 85 | 73 | 69 | 60 | 38 | 35 | 30 |
| 30 | 102,390 | 205 | 154 | 123 | 103 | 88 | 83 | 72 | 46 | 42 | 36 |
| 35 | 119,455 | 239 | 179 | 144 | 120 | 103 | 97 | 84 | 53 | 49 | 42 |
| 40 | 136,520 | 273 | 205 | 164 | 137 | 117 | 111 | 96 | 61 | 56 | 48 |
| 45 | 153,585 | 308 | 231 | 185 | 154 | 132 | 125 | 108 | 68 | 63 | 54 |
| 50 | 170,650 | 342 | 256 | 205 | 171 | 146 | 139 | 120 | 76 | 70 | 60 |
| 55 | 187,715 | 376 | 282 | 226 | 188 | 161 | 153 | 132 | 84 | 77 | 66 |
| 60 | 204,780 | 410 | 308 | 246 | 205 | 176 | 167 | 145 | 91 | 84 | 72 |
| 65 | 221,845 | 444 | 333 | 267 | 222 | 190 | 181 | 157 | 99 | 91 | 78 |
| 70 | 238,910 | 478 | 359 | 287 | 239 | 205 | 195 | 169 | 106 | 97 | 84 |
| 75 | 255,975 | 513 | 384 | 308 | 256 | 220 | 208 | 181 | 114 | 104 | 90 |
| 80 | 273,040 | 547 | 410 | 328 | 273 | 234 | 222 | 193 | 122 | 111 | 96 |
| 85 | 290,105 | 581 | 436 | 349 | 290 | 249 | 236 | 205 | 129 | 118 | 102 |
| 90 | 307,170 | 615 | 461 | 369 | 308 | 264 | 250 | 217 | 137 | 125 | 108 |
| 95 | 324,235 | 649 | 487 | 390 | 325 | 278 | 264 | 229 | 145 | 132 | 114 |
| 100 | 341,300 | 683 | 513 | 410 | 342 | 293 | 278 | 241 | 152 | 139 | 120 |
| 110 | 375,430 | 752 | 564 | 451 | 376 | 322 | 306 | 265 | 167 | 153 | 132 |
| 120 | 409,560 | 820 | 615 | 492 | 410 | 351 | 333 | 289 | 183 | 167 | 145 |
| 125 | 426,625 | 854 | 641 | 513 | 427 | 366 | 347 | 301 | 190 | 174 | 151 |
| 150 | 511,950 | 1025 | 769 | 615 | 513 | 439 | 417 | 361 | 228 | 209 | 181 |
| 175 | 597,275 | 1196 | 897 | 718 | 598 | 513 | 486 | 421 | 266 | 244 | 211 |
| 200 | 682,600 | 1367 | 1025 | 820 | 683 | 586 | 556 | 482 | 304 | 279 | 241 |
| 225 | 767,925 | 1538 | 1153 | 923 | 769 | 659 | 625 | 542 | 342 | 313 | 271 |
| 250 | 853,250 | 1708 | 1281 | 1025 | 854 | 732 | 695 | 602 | 380 | 348 | 301 |
| 275 | 938,575 | 1879 | 1409 | 1128 | 940 | 805 | 764 | 662 | 418 | 383 | 331 |
| 300 | 1,023,900 | 2050 | 1538 | 1230 | 1025 | 879 | 834 | 723 | 456 | 418 | 361 |
| 325 | 1,109,225 | 2221 | 1666 | 1333 | 1110 | 952 | 903 | 783 | 494 | 453 | 391 |
| 350 | 1,194,550 | 2392 | 1794 | 1435 | 1196 | 1025 | 973 | 843 | 532 | 487 | 421 |
| 375 | 1,279,875 | 2563 | 1922 | 1538 | 1281 | 1098 | 1042 | 903 | 570 | 522 | 452 |
| 400 | 1,365,200 | 2733 | 2050 | 1640 | 1367 | 1171 | 1112 | 963 | 608 | 557 | 482 |
| 450 | 1,535,850 | 3075 | 2306 | 1845 | 1538 | 1318 | 1251 | 1084 | 685 | 627 | 542 |
| 500 | 1,706,500 | 3417 | 2563 | 2050 | 1708 | 1464 | 1390 | 1204 | 761 | 696 | 602 |
| 1000 | 3,412,000 | 6833 | 5125 | 4100 | 3417 | 2929 | 2779 | 2408 | 1521 | 1393 | 1204 |
| 1200 | 4094400 | 8200 | 6150 | 4920 | 4100 | 3514 | 3335 | 2890 | 1825 | 1671 | 1445 |
| 1400 | 4776800 | 9567 | 7175 | 5740 | 4783 | 4100 | 3891 | 3372 | 2130 | 1950 | 1686 |
| 1600 | 5459200 | 10933 | 8200 | 6560 | 5467 | 4686 | 4446 | 3854 | 2434 | 2229 | 1927 |
| | | | | | | | | | | | |
| | | | | | | | | | | | |

Notes:

- The KW selections above are shown for convenience. A full selection of KW ratings from 1 to 1600 KW is available by entering the desired KW into the model number.

ELECTRICAL

$$\frac{\text{KW} \times 1000}{\text{Volts}} \div 1.73 = \text{Amps } 3 \Phi$$

$$\frac{\text{KW} \times 1000}{\text{Volts}} = \text{Amps } 1 \Phi$$

EXAMPLE: 150 KW at 480 V 3 Φ.

$$\frac{150 \times 1000}{480} \div 1.73 = 180 \text{ Total Amp Draw}$$

$$180 \div 48 \text{ Amps max circuit rating} = 3.75$$

Round up the number of circuits to 4

NOTE:

Each branch circuit is rated at a maximum of 48 Amps and each circuit is typically operated as an independent temperature step.



MODEL SH AND H SIZING INFORMATION

STEP 1

Solve for the unknown using the formulas stated below.

VARIABLES TO SOLVE FOR:

1. KW Requirement:

$$\text{_____ GPH} \times \text{_____ } ^\circ\text{F}\Delta\text{T} \times 0.00244 = \text{_____ KW}$$

2. Temperature Rise:

$$\text{_____ KW} \times 410 \div \text{_____ GPH} = \text{_____ } ^\circ\text{F}\Delta\text{T}$$

3. Flow Rate:

$$\text{_____ KW} \times 410 \div \text{_____ } ^\circ\text{F}\Delta\text{T} = \text{_____ GPH}$$

METRIC CONVERSIONS

$$\text{Liters} \times 0.2641 = \text{Gallons}$$

$$\text{Gallons} \times 3.79 = \text{Liters}$$

$$\text{Gallons} \times 0.003785 = \text{m}^3$$

$$\text{m}^3 \times 264.2 = \text{Gallons}$$

$$1^\circ\text{C } \Delta\text{T} = 1.8^\circ\text{F } \Delta\text{T}$$

$$^\circ\text{F} = (^\circ\text{C} \times 1.8) + 32$$

$$^\circ\text{C} = (^\circ\text{F} - 32) \times 0.556$$

$$\text{psi} \times 0.06896 = \text{Bar}$$

$$\text{Bar} \times 14.5 = \text{psi}$$

$$\text{psi} \times 6.86 = \text{kPa}$$

$$\text{kPa} \times 0.1456 = \text{psi}$$

$$\text{Lbs} \times 0.4536 = \text{Kg}$$

$$\text{Kg} \times 2.2 = \text{Lbs}$$

$$\text{Watts/Sq.Cm.} \times 6.4 = \text{Watts/Sq.In.}$$

$$\text{Watts/Sq.In.} \times 0.155 = \text{Watts/Sq.Cm.}$$

MODELS SH AND H NUMBER DESIGNATION

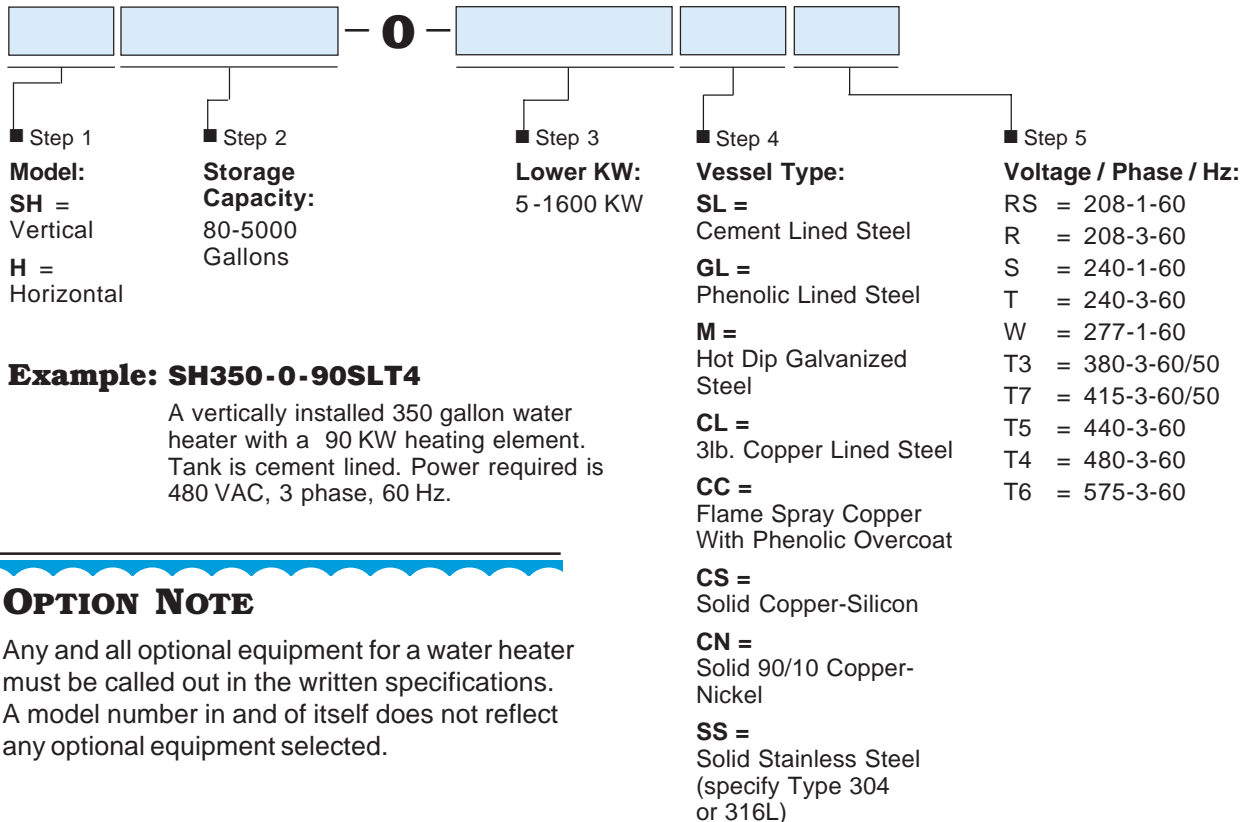

Example: SH350-0-90SLT4

A vertically installed 350 gallon water heater with a 90 KW heating element. Tank is cement lined. Power required is 480 VAC, 3 phase, 60 Hz.

OPTION NOTE

Any and all optional equipment for a water heater must be called out in the written specifications. A model number in and of itself does not reflect any optional equipment selected.

MASTER SPECIFICATIONS: MODELS SH AND H

JOB NAME _____

ENGINEER _____

REPRESENTATIVE _____

CONTRACTOR _____

GENERAL

Provide a quantity of _____ packaged type electric water heater(s) Model No. _____ as manufactured by HUBBELL The Electric Heater Co., Stratford, CT. The pressure vessel section, including the electrical control panel, shall be mounted on structural supports and be suitably insulated, jacketed, painted, and provided with lifting lugs. The entire unit is to be packaged ready for plumbing and electrical service connections and shall bear the UL listing mark certifying the entire water heater.

PRESSURE VESSEL

The pressure vessel shall be all welded construction and ASME Code Section IV stamped for a working pressure of 125 psi (**Optional Specifications:** *Select 100, 150, 160, _____ psi*) and contain a minimum of _____ gallons of storage. The storage vessel shall be carbon steel and lined with seamless Hydrastone cement applied to a minimum thickness of $\frac{5}{8}$ " on 100% of all interior tank surfaces (**Optional Specifications:** *Phenolic lined steel tank, 3lb/Sq.Ft. Copper lined steel tank, Hot dipped galvanized steel tank, Flame spray copper coated steel tank, Solid copper-silicon tank, solid 90/10 copper-nickel tank, solid Type 304 or 316L stainless steel tank*). The pressure vessel is to be completely covered with 2" thick "E" type energy conservation fiberglass blanket insulation and enclosed in a heavy gauge galvanized steel metal jacket finished in gray hammertone enamel. The vessel shall be protected by an ASME approved automatic reseating combination temperature and pressure relief valve set at the tank working pressure and 210°F.

RECOVERY

The recovery section shall be rated at _____ KW which will heat _____ GPH of water at _____ °F rise (_____ ° to _____ °F).

ELECTRICAL

The heater shall be designed to operate at _____ volts, _____ phase, _____ Hz, with a fused low voltage transformer providing 120 volt to all operating controls. The immersion heating element(s) shall be high quality copper sheathed (**Optional Specifications:** *Incoloy, Type 304 or 316 stainless steel, steel, Monel, Teflon, Inconel*) and sized to obtain the rated recovery. Each element circuit is to be independently operated through a definite purpose magnetic contactor having a resistive load rating equal to or exceeding the ampere rating of that particular circuit and shall be protected by individual power fuses rated at approximately 125% of the ampacity of the circuit. Multiple circuit elements shall be provided with a master terminal block for connecting of the incoming power feeds (**Optional Specifications:** *Built-in non-fused On/Off disconnect switch, Built-in circuit breaker with On/Off handle*). A safety door interlock switch shall interrupt power to the control circuit when the control panel door is opened. The control thermostat shall be immersion type and shall be consistent with the recovery rate of the heating element as to the number of steps required. A hi-limit control with a manual reset button shall be factory installed to disconnect all ungrounded conductors to the heating element(s) in the event of an over-temperature condition in the storage section.

In addition, the water heater shall be supplied with the following optional features:

- Option _____
- Option _____
- Option _____

WARRANTY

The water heater manufacturer shall warranty all electrical components against defects in workmanship and material for a period of one (1) year from date of start-up, and the pressure vessel for a full five (5) years Non Pro-Rated (**Optional Specification:** *full ten (10) years Non Pro-Rated*) from date of start-up, provided that the unit is started within three (3) months of date of shipment and installed and operated within the scope of the tank design and operating capability. Each water heater shall be shipped with a complete set of installation and operating instructions including spare parts list and approved drawing.

